

# ATX LED

**100% DC low voltage**

ATX LED Consultants Inc  
815-A Brazos #326  
Austin TX, 78701  
512 377 6052  
<http://atx-led.com>

## AL-WS-DR2C | AL-WS-DR2L

**Decorator switch style  
Constant Current LED  
driver and dimmer for Fans  
and tunable or fixed CCT LEDs**

**56 watt 3-Way**



### [Product Description - AL-WS-DR2C or DR2L wall switch](#)

This switch operates just like any standard residential light switch – however it takes 24-50v DC instead of 120VAC, and directly drives up to 56 watts of LED bulbs without additional drivers. This Decorator style switch in a standard residential style outline fits into any home, looks like any switch yet meets NEC article 411 for Low Voltage lighting.

Stand alone it operates as a simple switch for up to 8 single color or 4 tunable white LED's. For example, 8 LEDs with 6 watts each can be connected, 2 sets of 4 in series to each of the 2 outputs on this switch / dimmer device. Or 4 LEDs with tunable white. Use AWG 20/2 to connect to your LEDs in series – no CAT-5e tools are required to wire this device. Use AWG 16/3 or 18/3 to bring 48v ( or 24 to 52 volts ) and earth ground from a central power supply over to the switches. Daisy chain up to 100 watts on one home run – minimizes the number of home runs per project.

A proven rocker switch and brightness slider leverages mass production of decorator switches - now for Low voltage applications – a casual user requires no training, no App, no Internet to use this switch. Perfect, flicker free dimming from off to 1% to 100%. No network setup is required. Temperature feedback assures excellent dimming. Max current of 660 mA allows up to 28 watts per channel – two channels are provided for 56 watts total in single color mode.

For 3-way operation – a simple 2 wire link with AWG24 or better allows 2, 3, or an unlimited number of switches to control one set of LED's. Any single pole switch found at Home Depot can be used to add a 3-Way remote switch, or dual pole switch for an unlimited number of switch points. Momentary or rocker switches can be used

The AL-WS family includes many switch options. The AL-WS-DR2C can be field upgraded to WiFi with the AL-WS-Wifi chip

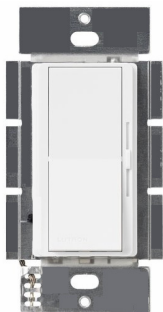

AL-WS-DR2

DALI bus and 56 watts



AL-WS-010v

DALI bus and 0-10v



AL-WS-Bath

Dual output LED  
and Bath fans



AL-WS-DR1

Low cost 24 watt driver



AL-WS-M

Switch for 3-way  
Momentary

Specifications

Power connectors ( dual )	Spring loaded connectors ( 2 pairs ) for AWG 16-20 wire – pass thru
LED constant current output	660 mA per channel – 2 channels 300 mA option available
Input voltage range	Spring loaded connectors ( 2 pairs ) 24v to 52 volts ( power for LEDs)
Standby power consumption	50 milliwatts (without WiFi) 200 milliwatts ( with WiFi )
Conversion efficiency	Over 95%
Protection	Reverse protection and static protection, short circuit and overfoltage, hot swap
Operating Temperature	0°C ~ 50°C
Size	108H (metal) 70H x 34 D x 42 W mm
Dimming	100% to 1%
FCC and interference	All outputs are RF filtered for minimal interference
Maximum output voltage	Input minus 4 volts
Minimum output voltage	6 volts - self calibrating
Minimum output current	1 mA = 0.16% dimming
Hot Swap	Yes – can unplug and connect LEDs with power applied.
WiFi Interface ( see DR2W)	Wiz / Signify option – change the back board for WiFi operation
N-Way input	To simple contact for 3-Way
PIR+	8 volt power to a PIR sensor

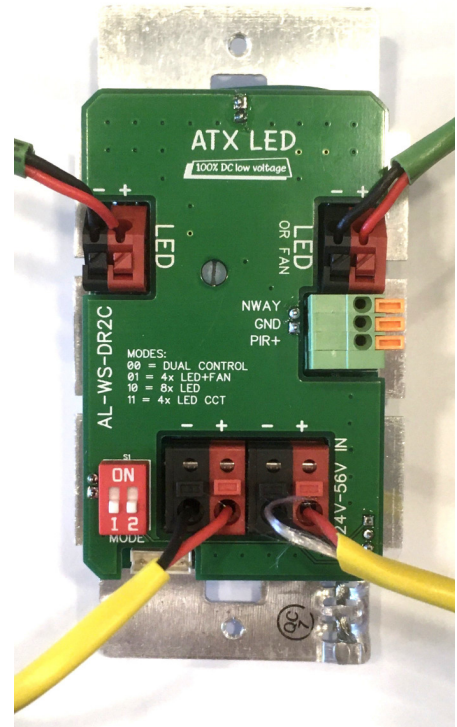

## Wiring the AL-WS-DR2C and DR2L for up to 8 LEDs

See <http://atxled.com/How2> for more examples

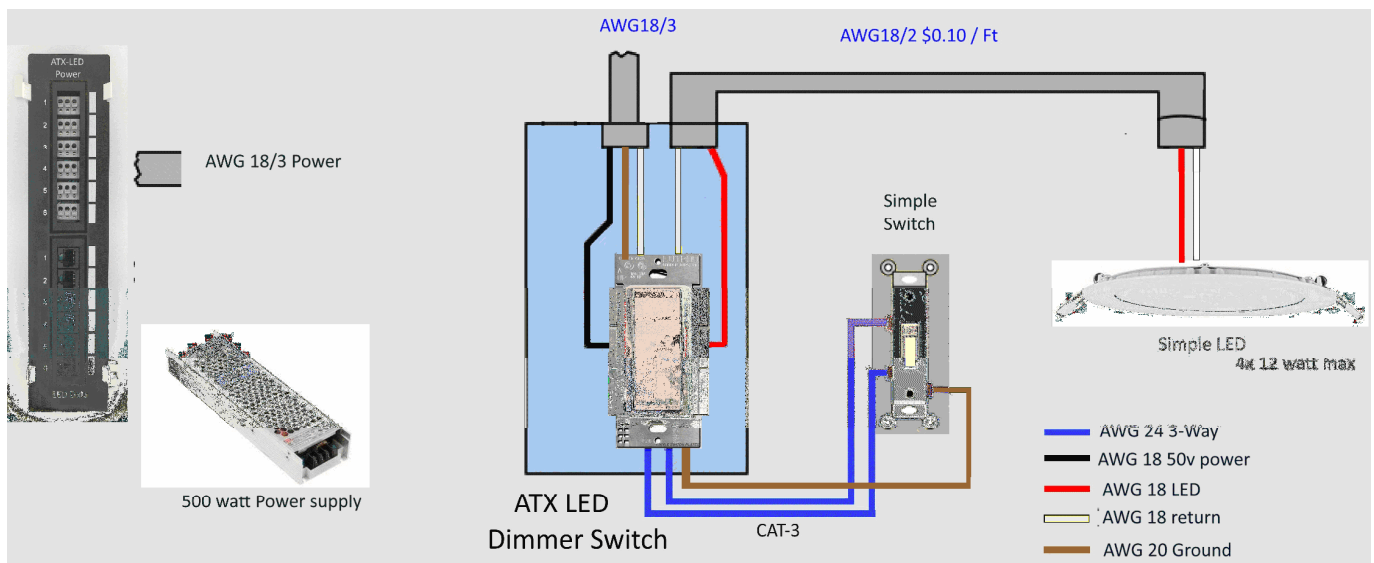

## Powering the AL-WS-DR2C or DR2L

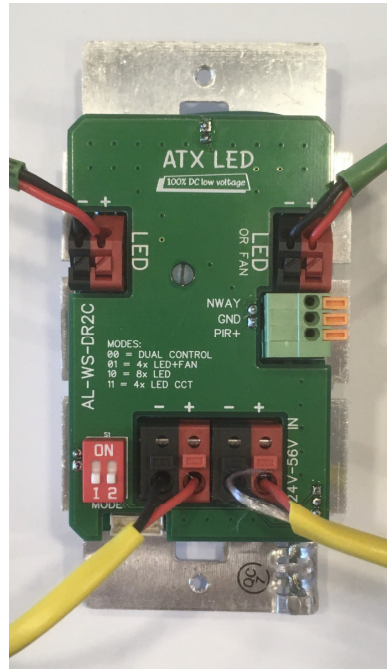

Power the switch via the Power input connectors, 48 to 52v is recommended. You can pass power thru from one set of power connectors to the other to avoid wire nuts in the box, up to 2 amps. When used with a 51 volt supply, voltage drop of up to 3 volts ( 150 ft of AWG18 wire) has no impact even with 60 watts of LED loads.

Shown here left is Yellow 18/3 for the power input and pass-thru to the next switch. Use the Ground for the metal plate.

Right is if using CAT-5e wire.

## Wiring the LEDs for Fixed Color Temperature LEDs

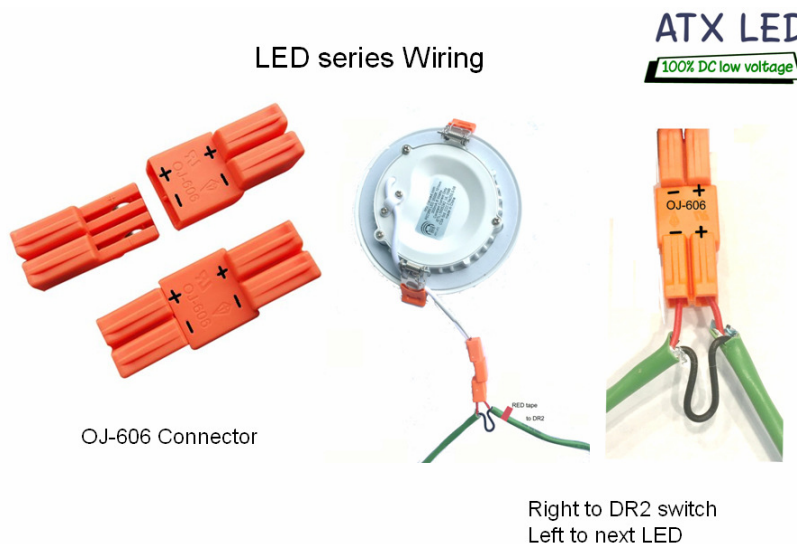

### Up to 8 LEDs with one color temperature

Green 18/2 wires go the 2 sets of 4 LEDs each (in series)

### The LEDs are wired in series

The simple strip and poke OJ-606 connectors are easy to install in ceilings.

If you only cut the Red wire – you can save time and work by wiring as shown at left – just 1 cut, 2 strips and insert.

Conventional wiring need 9 strips and 3 wire nuts per can.

## Tunable White LEDs

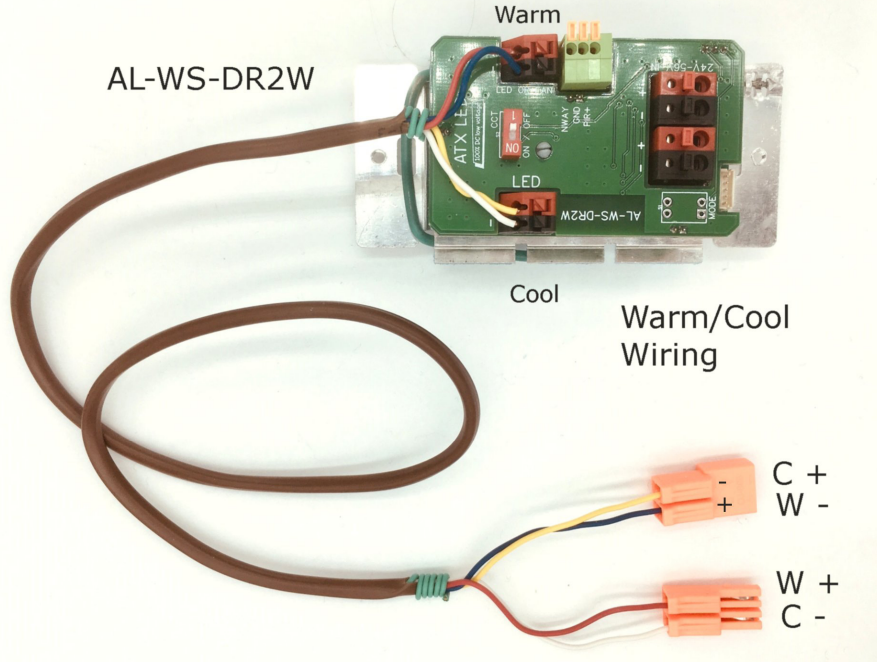

### Up to 4 LEDs with two color temperatures

Shown here is a AWG 20/4 wire with 4 conductors for tunable white

The wire colors we suggest are

Red/Blue – warm white  
Yellow/White – cool white

The Orange connectors twist the color sequence – note the photo left.

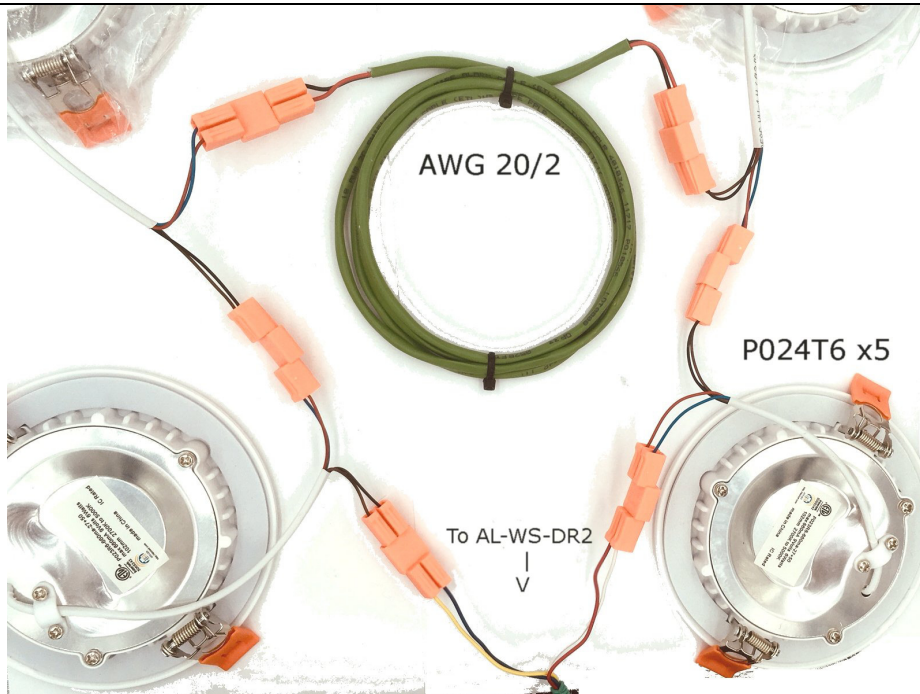

### From 1 to 4 tunable White LEDs can be wired in series

The first location needs 20/4 wire.

The other LEDs only need 20/2 between them.

Use Red/Black wire and match the +- markings on the orange OJ-606 connectors .



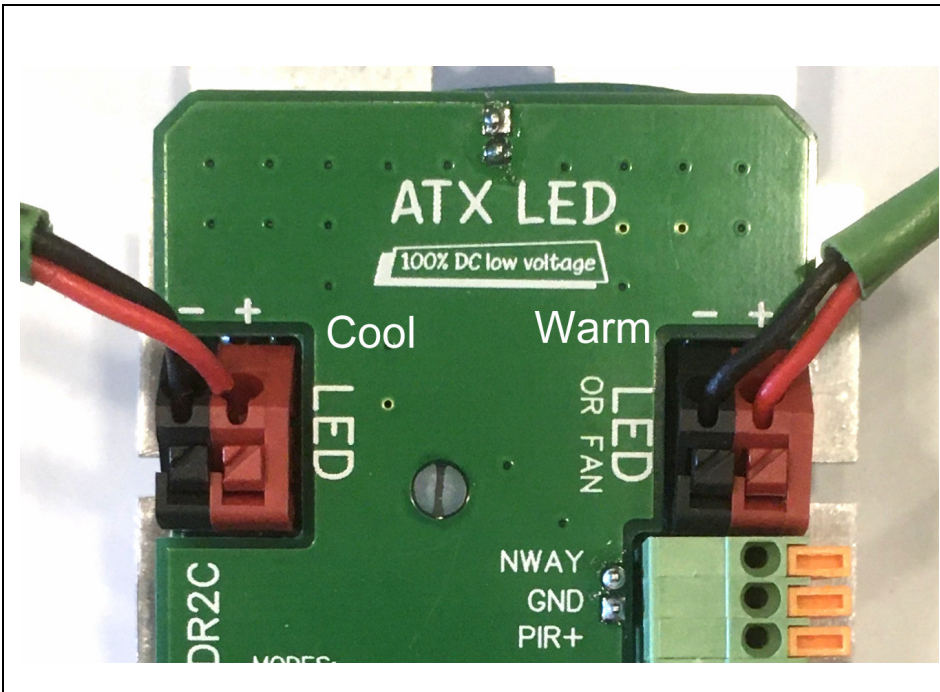

Detail of DR2C

The Right Red/Black connector is one string of LEDs ( Warm)

The Left Red/Black connector is the other string of LEDs ( Cool )

At the switch – the wires are in pairs

If you use different color wire then mark them with Red, White, Yellow and Black

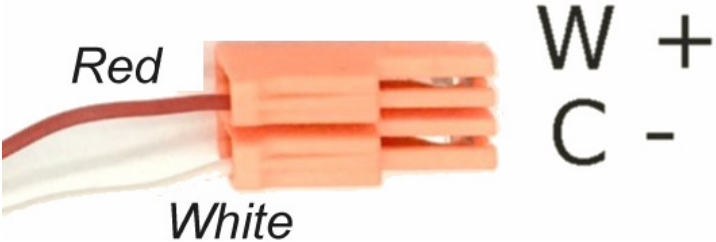
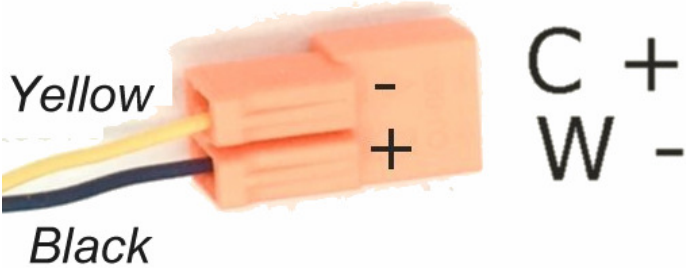

Tunable White LED wiring

If you use different color wire then mark them with Red, White, Yellow and Black

Notice that the connectors have each one string of each LED color temperature

# Basic wiring and operation

By default – the AL-WS-DR2C operates stand alone – no WiFi connection is required. Connect the dual LED outputs to your LED's. WiFi option is available.

## Constant Current LED operation

For up to 8 standard LEDs with 660 mA each – connect 1 to 5 in series to each side – the count does not need to match. Up to 58 watts is possible with 52 volts input and 5 leds with 9 volts each, with 48 volts input 4 LEDs can be connected.

For up to 5 Tunable White P023R6 LEDs – use the above diagram as an example. The Orange connectors go to the first junction LED position – jumper up to 4 LEDs together with simple 2 wire 18/2 jumper between the LEDs.

## Constant Voltage resistor LED operation

Note that CV leds use resistors that waste about 20% of the energy – so more Lumens are possible with CC leds than CV – but if CV is what you have ( Like LED strip lights) then CV mode must be used. The DR2 will detect CV mode at 12, 24 or 48 volts. Note: use a 52v power supply for 48v CV operation.

Maximum power with LED strips:

Strip Voltage	Max power with series wiring at 3 watts/ ft ( both LED outputs used, 51volt supply )	Max power with parallel wiring at 3 watts/ft
12 volts	3x series = 36 watts = 12 ft	16 watts = 5 ft
24 volts	2x series = 55 watts = 18 ft	32 watts = 10 ft
48 volts	55 watts = 18 ft	55 watts = 18 ft

## 12-24 volt DC bulb operation

You can buy on Amazon and 12v Monster, 12-24v bulbs with different formats. Technically these bulbs operate with DC-DC converters inside and can damage regular switches. You can safely connect 12 watts of these LEDs to the Fan output of the DR2C and operate them in dual switch mode. Select the FAN operation mode and the DR2C will detect that there is no fan, and operate these kinds of LEDs.

## Auto Calibration – First time Power up

Each time a AL-WS-DR2 turns an LED on, it tests if the connection has been changed, light added, light removed, light replaced. If a change is detected, the switch will recalibrate itself. This is a sequence of light levels that determine the features and abilities of the connected LEDs. It can detect Constant Voltage LEDs, Constant Current LEDs, LED strips and Fans. This also occurs when a new switch is installed for the first time. Please wait 2 minutes after initial power on, or after changing any LED, for the sequence to complete. Turn the LED off to complete the calibration. After that phase – the result is stored in on-board EEPROM and will be updated for temperature and aging changes over time. You can force the device to factory defaults from the switch front if needed ( see table below)

## Smart home and WiFi options available

For cloud management, Alexa and Google control, the AL-DR2C can be replaced by an AL-WS-DR2W anytime. If the installer ran 18/5 cable – then upgrading to full whole house automation is possible with the AL-WS-DR2 family products.

## Recommended ETL listed LED's

LED rated watts	Type	Model	Size inches *	LED rating	Max Count @51v	Total power output Watts	Note
6	Flat Ceiling	P023R6	3 / 5	660 mA	10	60	2x 5 series
6	Flat Ceiling	P023R6 CCT	3 / 5	660 mA	5	30	5 in series
12	Flat Ceiling	P023R11	6 / 7.5	1440 mA	10	65**	2x 5 in series
12	Flat Ceiling	P023R11 CCT	6 / 7.5	1440 mA	5	32**	5 in series
6	Recessed	DL-120	1 / 5	660 mA	10	60	2x 5 in series
6	Recessed	DL-120 CCT	1 / 5	660 mA	5	30	5 in series
6	Gimbal Spot	MS31008	3	660 mA	10	60	2x 5 in series
6	Bulb	ATX-A60	E26	660 mA	10	60	2x 5 series
6	Bulb	ATX-C35	E12	660 mA	10	60	2x 5 series
6	Bulb	E26-48v6w	E26	120 mA	12	72	12x Parallel
14	Closet	FMMCL 18 840 S1 M4	18	360 mA	2	28	1 per channel
7	Closet	FMMCL 840 S1 M4	7	360 mA	4	28	2x 2 in series
12	Linear	P023S12	18	1440mA	12 ft	65**	2x 5 series
12	linear	P023S12 CCT	18	1440mA	6 ft	32**	2x 5 series
35	Strip	GL-24-LH99A DC48v	195	700 mA	30 ft	70	1 per channel
35	Strip	GL-24-LJ01A DC48v CCT	195	700 mA	15 ft	35	1
6	Outdoor Small	ODB6	5	660 mA	10	60	2x 5 series

\*size 3 / 5 means 3 inch light source and 5 inch trim diameter

\*\* these 12 watt LEDs will operate at 6.5 watts each when used with the DR2 at 720 mA.

Any 24 or 12 volt CV strip can be connected, the DR2 will detect a CV strip LED and operate in CV mode. For best results, connect 12 volt strips in series to reach 48 volts ( 4 in series) or connect 24 volt strips 2 in series.

Note: 360 mA LED with 6 watts – 2 per channel, 4 total, 360 mA LED with 9 or 12 watts – one per channel, two total. Contact us for information on our Doubler device to support 300/360 mA LEDs.



## Momentary or On/Off Main Switch operation

The main switch of the device can be either On/Off type or Momentary. On/Off has the dimmer on the right, Momentary is installed with the dimmer on the left. The difference is that each press of the Momentary style causes the light to turn On/Off.

### Functions – Momentary Main switch

If your AL-WS-DR2 has a Momentary switch then use this table. Note – the slider should be on the left

Function	Seconds	How to trigger
On / Off	0.5 max	Push the switch down for under ½ second. The light will turn on and off each time you press.
Adjust Color Temperature	< 45	Hold the button down – move the slider. The Slider now controls the color temperature – each time you move the slider – the 45 second timeout is extended.
Reset to defaults: - Recalibrate the LED currents - Set switches to On/Off style	45	Press and hold the button for 45 seconds. The switch will enter self calibration mode the next time the light is turned on. Self Calibration will also be done if the number of LEDs attached changes. The switch method will change back to On/Off type
Wrong switch type: Restore to Momentary Operation	0.5 x 5	After factory default, press the button 5 times with less than 0.5 seconds each to change from On/Off to Momentary operation.
Put WiFi into pairing mode	Until light level change	Set the slider to minimum dim, press and hold the switch down for about 7 seconds – the lights will step up to 50% and the WiFi chip will enter pairing mode. If already connected to wifi – nothing happens.

### Functions – On/Off style Main switch

If your AL-WS-DR2 has an Up/Down On/Off switch then use this table. Note – the slider should be on the right.

Function	“Flips”	How to trigger
Wrong switch type: Changing operation to Momentary	5	After a factory reset - press a momentary switch 5 times briefly to program the device for momentary operation. Both the built-in and remote switches can be either On/Off or momentary. The face plate can be exchanged in the field if needed.
Adjust Color Temperature		If the LED is off – move the slider. The light will turn on and you can adjust the color temperature. After adjusting the color temperature – turn the switch ON, and you can adjust the brightness. Turn the switch off and the color temperature and brightness will be saved.
Reset to defaults: - waiting to calibrate - switches are On/Off type	8	Set the dim to low dim. Turn the switch on for 2 seconds. Now off and on 8 times, quickly, leaving it on after the last flip. The brightness will change to 50%, then go off The switch will enter self calibration mode and the lights will flash.
Put WiFi into pairing mode	5	Set the dim to low dim. Turn the switch on for at least 2 seconds. Now turn off briefly off and on 5 times, quickly, leaving the switch up on the 5 <sup>th</sup> flip. The Slider now controls the color temperature

## Setting LED Operational Modes

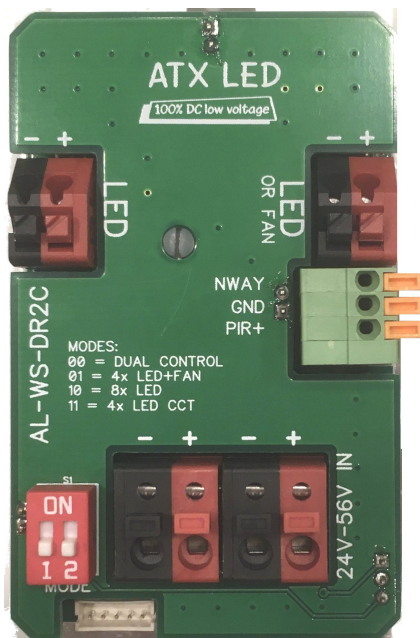

By default – the AL-WS-DR2C or DR2L operate stand alone – no WiFi connection is required. Connect the dual LED outputs to your LED's. For up to 8 standard LEDs with 660 mA each – connect 1 to 4 in series to each side – the count does not need to match. Total is 8 x 660 mA x 44 volts or 58 Watts maximum. With the P023R6, 8 LEDs is 48 Watts.

For up to 4 Tunable White P024T6 LEDs – use the above diagram as an example. The Orange connectors go to the first junction LED position – jumper up to 4 LEDs together with simple 2 wire 18/2 jumper between the LEDs.

The device is factory calibrated for operation. After power up – you will see a 2 second ON time with the lights at a very low dim level while it learns the capability of the attached LEDs in your installation. After that phase – the result is stored in on-board EEPROM and will be updated for temperature and aging changes over time. You can force the device to factory defaults from the switch front if needed ( see table below)

## Operation Modes – DIP switches

Two dip switches select the 4 operating modes – Both ON for CCT, Both OFF for dual LED control, 1 ON for 8x LED and only 2 ON for 24 watt LED plus Fan. Tunable White LEDs can be adjusted from 2700K to 5000K and are connected as shown in our wiring diagram. If you are in CCT ( tunable white ) mode and use 8 fixed color LEDs, you will see odd behavior, the lights will not be all at the same dim level. Change the switch and reboot.

## Operation Modes - 8 fixed LEDs

Set the dip switches to 8 LED operation and all 8 attached LEDs will have the same current – from 1 to 8 LEDs can be attached, the N-WAY input operates as a 3-way switch.

## Operation Modes - 4 CCT LEDs

If the LED is off – move the slider. The light will turn on and you can adjust the color temperature. After adjusting the color temperature – turn the switch ON, and you can adjust the brightness. Turn the switch off and the color temperature and brightness will be saved. The N-WAY input operates as a 3-way switch.

# Slider Operation

The Slider for dimming has 3 functions in this device.

- A) it changes the brightness of the LEDs when the switch is ON.
- B) it changes the color temperature if you have CCT enabled. Moving the slider with the light OFF changes the color temperature. Turn the switch on to exit color temperature operation
- C) it returns the switch to UP = ON operation. If the main switch is UP and you move the slider, the lights will turn on. This compensates for the 3-way effect that leaves the switch with the light on when the switch is down.

# Dual LED Control

Set the dip switches to Dual operation. The built-in switch will control the left output and the N-Way input will control the Right LED and expect a LED as the load ( no Fan! ). If an On/Off switch is used, the dimmer level will be the same for both. With a momentary remote – it will operate as On/Off and press/hold to dim. If the remote is not momentary – then the On/Off switch action is reversed ( open is ON). The device will learn if the remote switch is momentary or On/Off. See below.

# Fan Connection

A SLM70-LVDC or similar fan can be connected to the Right Led/Fan output. It will be automatically detected and operation will be in Automatic, manual or timer mode as described below in the N-Way section. The DR2 in fan mode has a 12 volt output and the SLM70-LVDC has a 4400 uf input capacitor that allows it to be automatically detected. 12v fans with lower capacitance may not be detected, this will place the output into 660 mA mode with more that 12v during power up likely.

# Trouble Shooting

If the LEDs do not turn on at full brightness, or flash – please check common causes;

1. Flashing the first time the light is turned on, or if the number of LEDs per side changes, is part of self calibration, please wait 1 minute for this to complete.
2. If no light – then the number of series LEDs is exceeded. The forward voltage of the LEDs is too great. The delivered voltage is between 7 and 42 volts ( with a 48 v supply) or 46 volts ( with a 52 volt supply). Check the forward voltage of the LEDs and add them up. For example, a 6 watt 360 mA bulb has 18 volts forward, a 6 watt 660 mA bulb is 9v.  
  
if your LEDs add up to more than 42 or 46 volts - they will not turn on at full brightness, and might not turn on at all.
3. Cross wiring. If the + of one side is connected via the LED to the – of the other side – then the LEDs will cycle on/off every 4 seconds.
4. If CCT LEDs are used and the CCT switch is Off – the colors will not change, and the LEDs will operate at 12 watts instead of 6 watts – it could be intended by the installer to operate at 12 watts per bulb for example with a P023R11 6 inch fixture. Operating a 6 watt fixture at 12 watts. will decrease bulb life and could overload the home run to the power distribution panel.
5. If cable is used that is not copper ( see CCA anywhere on the box ? ) then there will be substantial loss in the wire. Please do not use CCA type wire of any kind
6. If the FAN does not turn on – note that the switch options need to be set to enable the FAN.

## N-Way input Options and wiring

The N-Way input has several functional options. A simple low cost switch or alarm contact can be used to activate this. The options are: 3-Way, Dual Output, and Fan Control. Default is simple 3-Way. If the WiFi module is installed – only 3-Way is available.

### 3-Way Operation ( On/Off remote switch )

Simply connect an AWG24 (solid CAT-3 or better is recommended) between the N-WAY pins and a remotely installed standard On/Off wall switch. If more control switches are needed – use a dual pole 3-Way setup, 4-Way is also possible. No controller is required; an unlimited number of switches can control one light. See our online application note for 3-Way switching. The N-Way input is has an internal pull-up – so a connection to ground will change state. The state of the N-Way input is XOR'd with the physical switch.

Note: install a Rocker type switch upside down. Turning the switch UP opens the circuit and turns the light on if the main switch is down.

### Door Jam Operation

Unless Fan mode is enabled, a simple Normally Open door alarm switch can be wired to the N-Way input. Then – when the door opens – the light will go on.

### PIR – detect motion operation ( DR2L )

If an external PIR device is attached – when the output is High – the Light will turn on until the PIR input goes low again. For slow-on operation. Please see the AL-WS-DR2L – this will turn the Light on at a low level with PIR occurs.

### Fan Switch Operation

Fan operation supports two types of switches, and also operation without a fan switch.

#### **For On/Off type switches:**

- A) Manual. In this mode – leaving the fan switch off keeps the fan off. You can turn the fan on/off anytime by turning the switch on or off. It will turn on immediately and stay on 10 minutes after the light is turned off. Turn the fan switch off to return to manual mode.
- B) Timer. If the fan switch is left on, then each time the light is turned on, after 90 seconds the fan will turn on and stay on for 10 minutes and turn off automatically.

#### **For momentary switches (see how to convert from On/Off to momentary)**

- A) Press to start: each press adds 5 minutes run time, enables automatic operation
- B) Press long to stop: press for 4 seconds and release to stop the fan, disables automatic operation
- C) Automatic operation: Each time the light is turned on, after 90 seconds the fan will turn on and stay on for 10 minutes and turn off automatically. Press for 4 seconds and release to stop the fan now and exit automatic operation.

#### **For operation with no fan switch,**

- A) Wire the N-way pin to the Gnd pin. The fan will operate in Timer mode, otherwise it will not operate.

## N-Way Operations

A remote switch can be used, it can be either an On/Off style or push button (momentary contact) style. The AL-WS-DR2 can detect the type of switch and operate as expected. With the Momentary method enabled – each momentary short of the N-Way pin to Gnd will toggle the light on / off. To enable this mode ( if not already set) – use an AL-WS-M or RH-253 or similar momentary switch and press it 5 times after power is applied.

### Remote Switch Functions – Push Button style

Function	Seconds	How to trigger
On / Off	0.5 max	Push the switch down for under ½ second. The light will turn on and off each time you press.
Remote Dimming	< 10	Press and hold the button to dim down, then up. To dim down again, release and press. Do not hold longer than 15 seconds.
Return to On/Off style	45 seconds	Should the switch get confused and act in toggle mode when the switch is On/Off – simply leave On for 15 seconds and the system will correct the error.
Changing from On/Off to Momentary	5	If a AL-WS-DR2 with a momentary switch is operating in On/Off style – then press the rocker 5 times briefly – 1 second between presses - it will switch to Momentary operation.



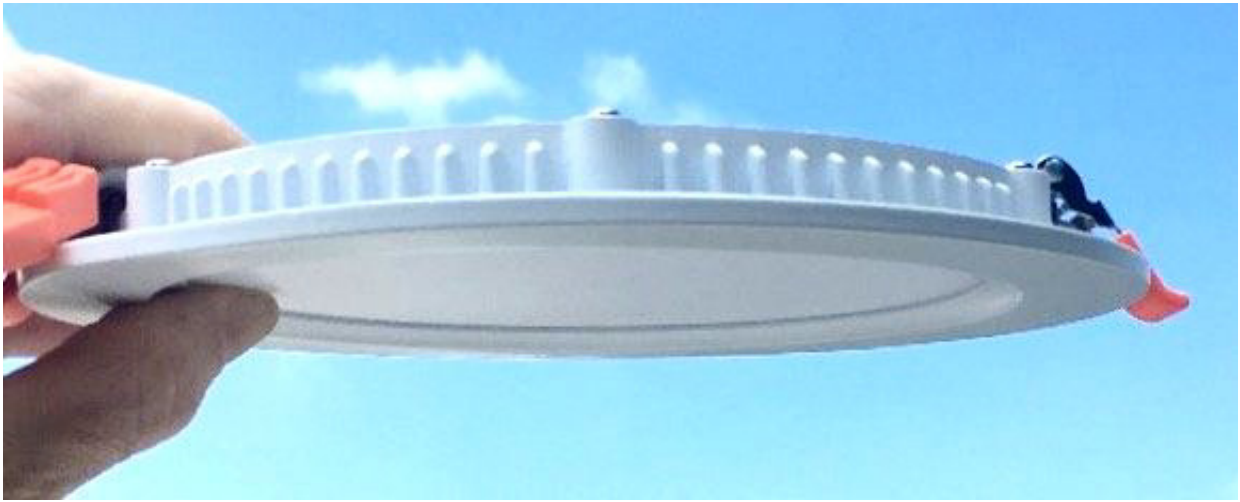

### Remote Switch Functions – On/Off style

Function	“Flips”	How to trigger
Remote Dimming		Not supported
Changing from On/Off to Momentary	5	If a AL-WS-DR2 with a momentary switch is operating in On/Off style – then press the rocker 5 times briefly – it will switch to Momentary operation.
Return to On/Off style	45 seconds	Should the switch get confused and act in toggle mode when the switch is On/Off – simply leave On for 45 seconds and the system will correct the error.



## Product Description - low profile long life LED fixture

The P023R series of LED fixtures are ETL listed and IC rated for direct contact with insulation – recognizing it's cool operating temperatures and distributed heat ( no hot spots).

Trim Diameter	Color Temperature	Feature	Connector	Watts	Image
5	2700, 3000, 3500, 3850, 5000 K or tunable	Slim Disk	OJ-606	6	
7 1/2	2700, 3000, 3500, 3850, 5000 K or tunable	Slim Disk	OJ-606	11.5	
4	3000 K or 3500 K	Gimbal	wire	6	See MS31008
5	3000 K or 3500 K	Spot	LeverNut	6	See DL-120
A60F Frosted	3000K, 3500K	Bulb	E26	6	
A60 Filament	2700 K, 3000K, 3500K, 4000K	Bulb	E26	6	
C35 Filament	2700 K, 3500K 4000K	Bulb	E12	6	
18 inch	2700, 3000, 3500, 3850, 5000 K or tunable	Linear	OJ-606	12	



# Power Distribution kit – AL-PSE6

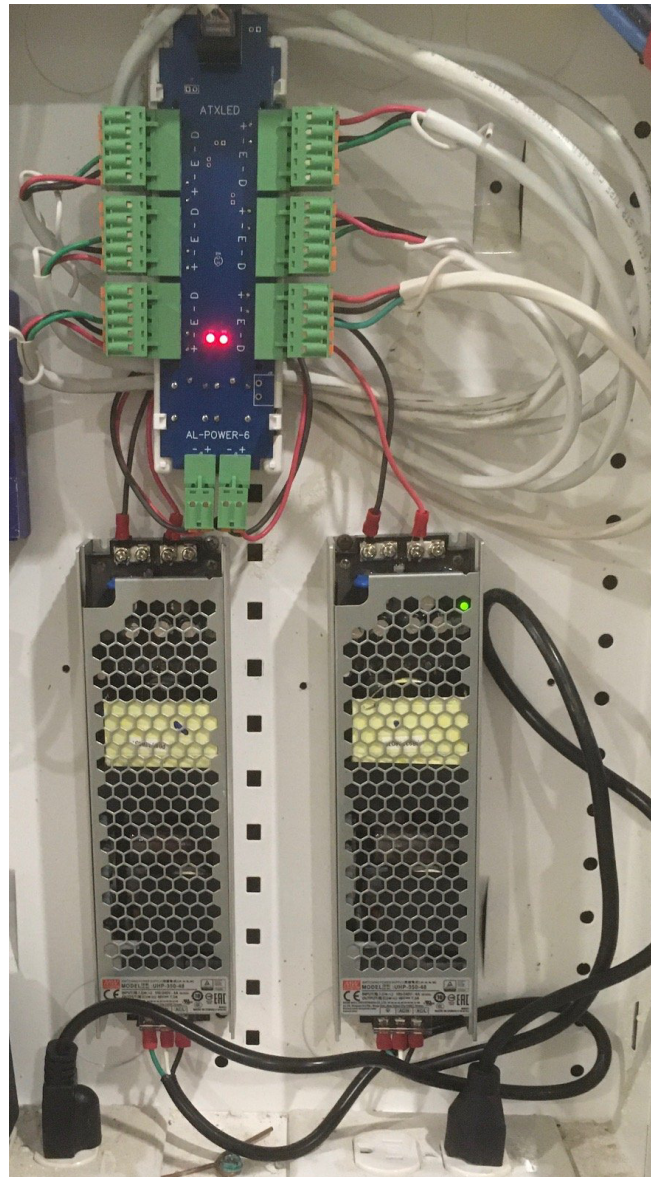
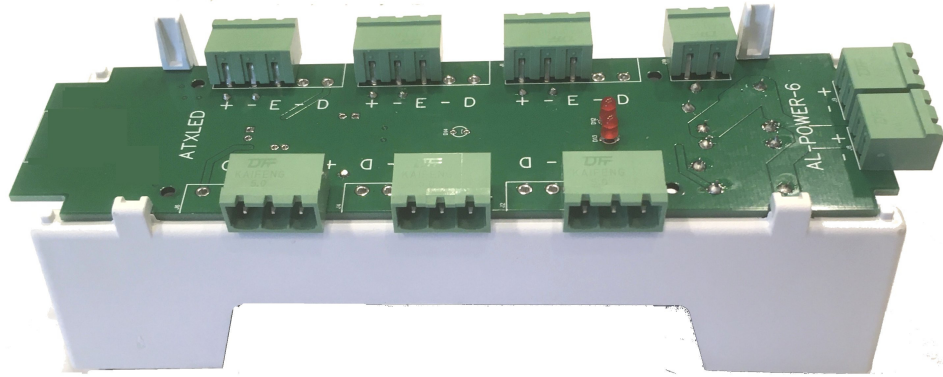

# ATX LED Product family

